

GLIDE

Rehabilitation Products

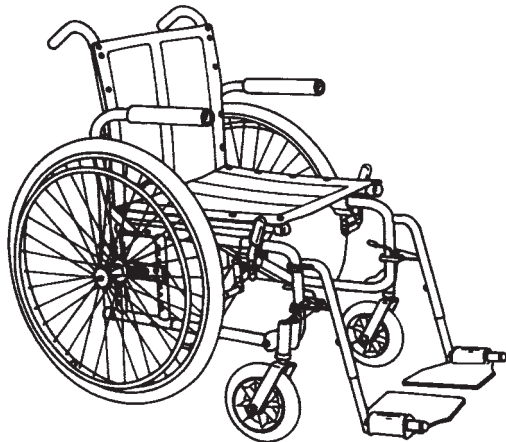

G2 SERIES

OWNER/USER MANUAL

**FOR YOUR SAFETY
AND COMFORT READ
CAREFULLY AND
UNDERSTAND ALL OF
THE FEATURES PRIOR
TO USING YOUR NEW
MANUAL WHEELCHAIR**

Maximum recommended user
weight 150kg

GLIDE

Rehabilitation Products

TABLE OF CONTENTS

SECTION	DESCRIPTION	PAGE
1	INTRODUCTION	1
2	GETTING ACQUAINTED WITH YOUR CHAIR	2
3	BACKREST AND SEAT UPHOLSTERY	3
4	ARMREST	4
5	FOOTPLATES	5
6	FORKS AND CASTORS	6
7	CASTOR ALIGNMENT	7
8	WHEELS	8
9	BRAKES	9

SECTION	DESCRIPTION	PAGE
10	REAR WHEEL POSITION	10
11	FOLDING AND OPENING THE WHEELCHAIR	11
12	CROSS BRACE	12
13	TYRES/CASTOR TYRES	12
14	OPERATION OF WHEELCHAIR	13-15
15	TRANSPORTING YOUR CHAIR	16
16	OPTIONS	17
17	SERVICING	18
18	WARRANTY	19-21

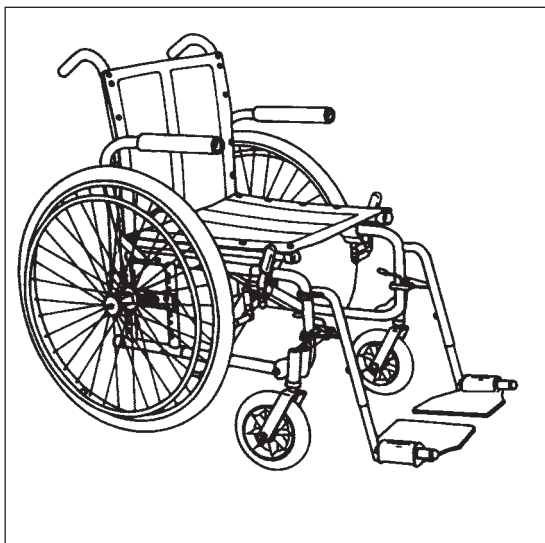
**1****GLIDE**

Rehabilitation Products

SECTION 1

INTRODUCTION

Thank you for choosing the Glide G2 Manual Wheelchair.

An Australian designed and manufactured product which complies with AS 3695 and EN 12183 Standards (Type B classification) and has a manufacturers recommended user weight of 100kg. Heavy Duty G2 150kg maximum user weight.

With proper care and operation, your G2 chair will provide years of trouble free use.

Please take the time familiarise yourself with the functions and features of your chair by reading this owner/user manual. If you have any queries about the functions of the chair you can call Glide Rehabilitation Products or your nearest Glide Rehabilitation Products dealer.

Glide Rehabilitation Products

+61 8 9345 3400



Rehabilitation Products

SECTION 2

GETTING ACQUAINTED WITH YOUR MANUAL WHEELCHAIR

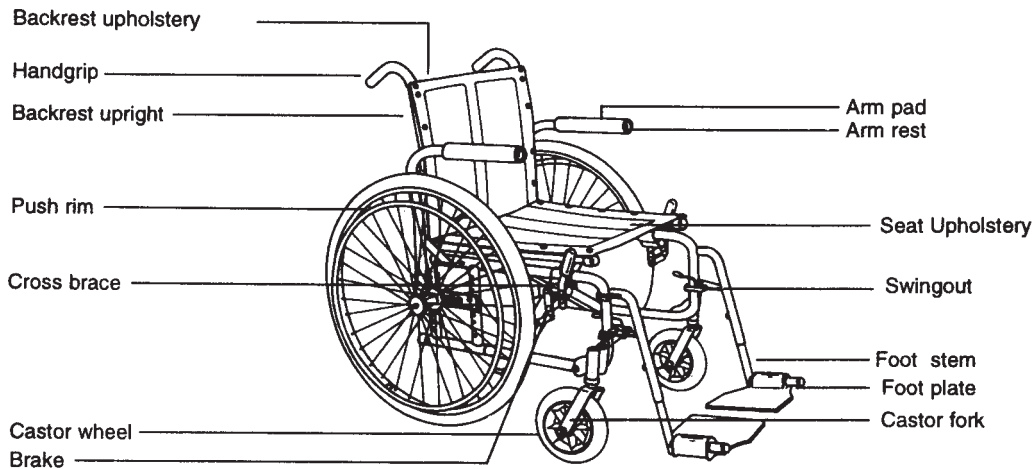

GLIDE

Rehabilitation Products

SECTION 3**UPHOLSTERY**

With proper care your upholstery should give years of trouble free service. It is very important to read the following:

- Regular (weekly) cleaning of back and seat upholstery is very important to remove body oils which can cause hardening of the upholstery.
To clean, wipe with a cloth or sponge, which has been moistened in warm soapy water, and then dry with a soft, clean cloth. The use of mild non-abrasive pure soap is recommended. Stubborn grime may require gentle scrubbing with a soft brush.

Warning

- Never use furniture polishes, abrasive cleaners or steel wool.
Regular use of cleaners containing hydrocarbons or similar additives may cause damage to the upholstery and harden the surface.
- Always replace broken upholstery screws immediately to avoid possible tearing.
- Stretched, torn or split upholstery must be replaced for safety reasons.

GLIDE

Rehabilitation Products

SECTION 4

ARMREST (FULL LENGTH STYLE)

To remove:

- Push button and hold in on front arm socket.
- Using other hand lift armrest upwards.

Note: Wheelchairs may be supplied without button locks.

To install:

- Replace armrest into front and rear arm sockets, push button in and armrest down simultaneously.
- Ensure armrest is secure and button has popped out.

WARNING

- Never lift wheelchair by armrest as damage may occur.

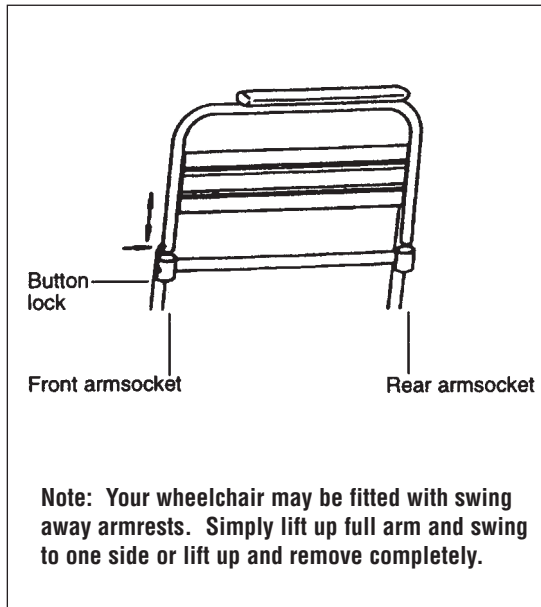

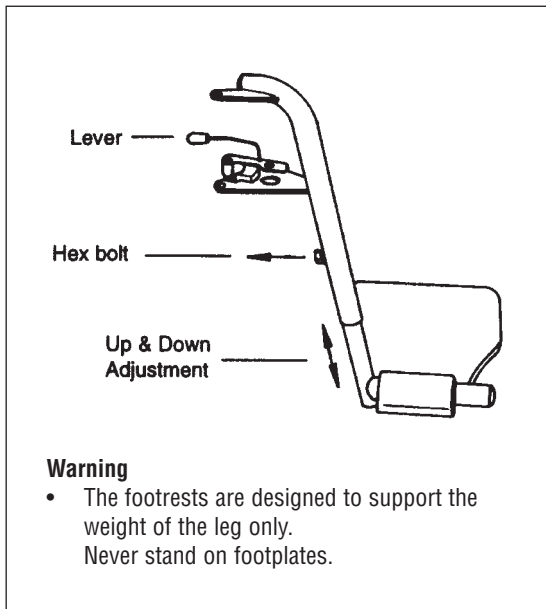
**GLIDE**

Rehabilitation Products

SECTION 5**FOOTREST**

To remove:

- Push lever inwards to unlock and swing outwards.
- Lift upwards to remove.

To install

- Insert footrest back on the two locating pins and swing inwards for automatic locking.

To adjust footplates

- Remove hexagonal bolt.
- Move up or down. Line up the nearest hole for the desired height.
- Replace hexagonal bolt and tighten.

GLIDE

Rehabilitation Products

SECTION 6

FORKS AND CASTORS

Assembly

- Press bearing housing into bottom of castor tube.
- Press castor bush into top of castor tube.
- Slide castor pintle through bearing housing and castor bush.
- Place circlip on castor pintle.
- Slide bearing on pintle and locate in bearing housing.
- Screw hex-nut until there is 1mm of up and down pintle movement.
- Place castor fork in position and tighten locknut.

Important

Once tightened ensure 1mm of up and down movement and castor turns freely.

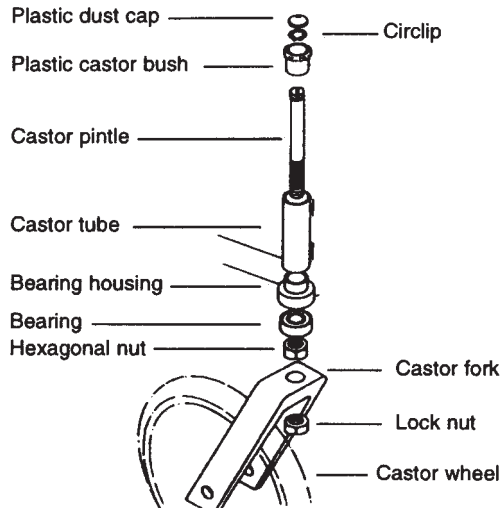

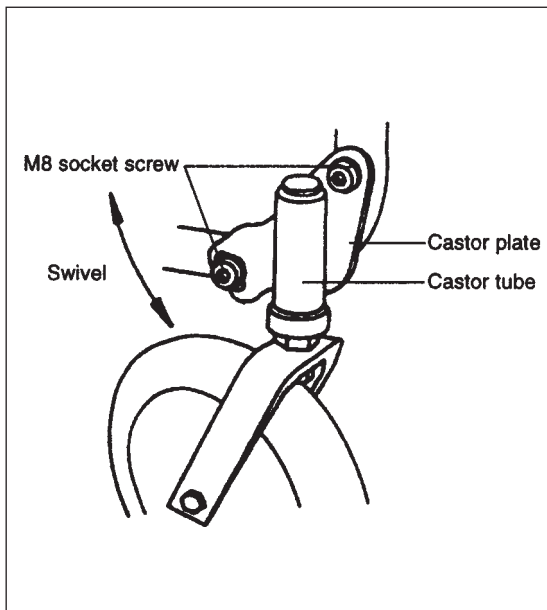
**GLIDE**

Rehabilitation Products

SECTION 7

CASTOR ALIGNMENT

- Incorrect castor alignment will render the wheelchair difficult to steer and propel. Alignment should be checked when rear wheels have been repositioned or if castors have had a heavy knock. (e.g. ramming kerbs).

Adjustment

- To adjust, place wheelchair on a level ground and loosen both M8 socket screws until castor plate can swivel. Using a square, set castor tube at 90 degrees to the ground and lock in position.
- When both castors are set, ensure all screws are tight before use

GLIDE

Rehabilitation Products

SECTION 8

The large wheels are fitted with sealed ball bearings and should last many years without replacement.

Large Wheels (fixed)

- To remove large wheels unscrew locknut and using a large screwdriver unscrew axle and remove when free.
- Installation is the reverse procedure.

Large Wheels (quick release)

- To remove large wheels (quick release) push button in and slide wheel out while button is still pushed in.
- To install push button in and slide wheel in.
- Wheels should be removed weekly and axles and sockets wiped clean with a soft cloth to avoid jamming in socket. Smear axle with dri-lube stick before replacing.

Warning

- Do not use wheelchair, unless button is fully out when wheels are in place.

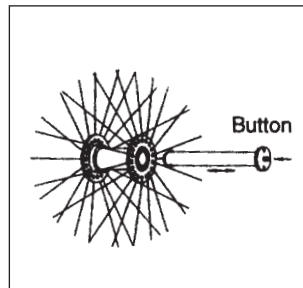
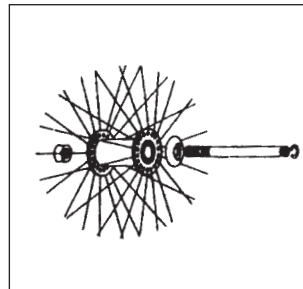

GLIDE

Rehabilitation Products

SECTION 9**BRAKES**

- Brakes are designed as a locking device only and should be applied when the wheelchair is stationary. Do not use brakes for slowing the wheelchair. Use the push rims as a means of braking.

Adjusting brakes

- Inflate tyre to correct pressure before making adjustment to brakes.
- Loosen locking screws on brake body and adjust brake pad so when lever is in the locked position the wheel is firmly locked.
- Re-tighten lock nuts.
- Check that, when both brakes are applied, the wheelchair will not roll. If rolling occurs re-adjust.
- When brakes are in the off position the pads should not rub against the tyre.

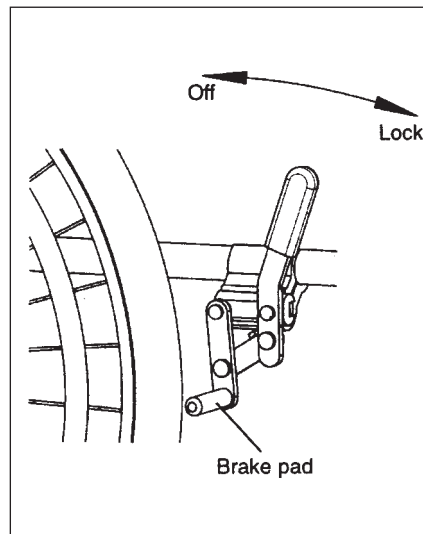

GLIDE

Rehabilitation Products

SECTION 10

REAR WHEEL POSITION

The rear wheels are adjustable both vertically and horizontally.

To adjust vertically

Remove rear wheels and the 4 bolts holding the axle plate. Move plate up or down to the required height. Replace bolts and tighten. Avoid over tightening of bolts, as the frame may be damaged.

To adjust horizontally

Remove rear wheels and axle plate from frame. Remove axle socket and place in the required hole. Half hole adjustments can be achieved by reversing axle plate. Replace axle socket and tighten.

Caution

Increasing the seat fall or moving wheels forward will greatly affect the stability of the wheelchair

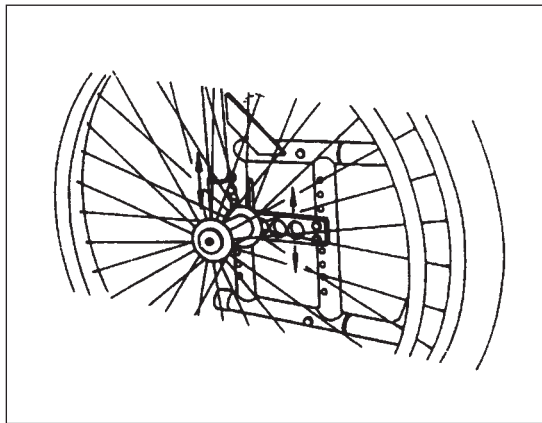

GLIDE

Rehabilitation Products

SECTION 11

FOLDING AND OPENING THE WHEELCHAIR

Opening

- Standing in front of the wheelchair, using two hands slowly press down on both seat tubes keeping both hands on top of the seat at all times. As the wheelchair folds out you will notice more pressure is required to open the chair until it reaches a point where it will suddenly snap into position.

Caution

Never wrap hands around seat tube when opening the wheelchair or have any part of the hand protruding further than the seat width as injury may occur.

Folding

- Before folding flip footplates to the up position.
- Standing to one side of the wheelchair, grasp the seat upholstery front and rear approximately centre and lift upwards. You may find that a quick jerking action may be necessary for the chair to release from the locked out position.



Rehabilitation Products

SECTION 12

CROSSBRACE

- The cross brace centre bolt should be kept tight. Over tightening will make wheelchair difficult to fold.

SECTION 13

TYRES/CASTOR TYRES

- Worn and under inflated tyres will render the wheelchair difficult to steer and propel. Large wheel tyres and castor tyres should be only replaced as pairs.

ANTI-TIP WHEELS

- When anti-tip wheels are required, please contact your nearest Glide Rehabilitation Products dealer for correct fitting procedures.

WARNING - interference with kerbs may occur when anti-tip wheels are fitted.

GLIDE

Rehabilitation Products

SECTION 14



OPERATION OF WHEELCHAIR

If there is a need for a lap type posture restraining belt to be fitted to the G2 Wheelchair Chair we recommend that you contact your nearest agent or Glide Rehabilitation Products direct for correct fitting procedures.

On downgrades, the body should be in a straight position and the speed and direction of the wheelchair controlled by the push rims (not brakes).

Under normal conditions (clean dry surface with no side chamber) it is possible to climb slopes safely of up to 13 degrees.

Caution

- Maximum safe slope 11 degrees

GLIDE

Rehabilitation Products

SECTION 14 - 1

OPERATION OF WHEELCHAIR

Crossing obstacles

If you are a first time user or don't have the physical strength, it is advisable to have an attendant assist you while crossing obstacles (e.g. sidewalk kerb). The attendant can tilt the chair back using the hand grips and the rear tilt bar, then pushing large wheels as far as the kerb, then lifting the wheelchair up over the kerb.

If you are an experienced user and have the physical strength, the following method may be used. Place the wheelchair in front of the kerb. By moving the push rim quickly forward, the castors will lift and the chair will surge forward enabling you to place the castors on top of the kerb. Then by leaning forward ease the rear wheels up the kerb. If footplate touches obstacle, perform same operation but lift the front castor just before the obstacle is reached.

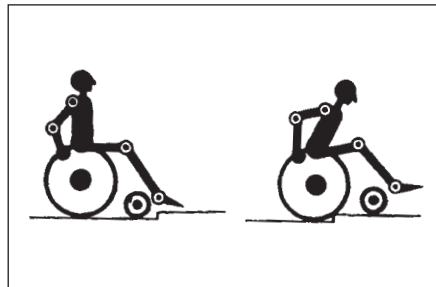
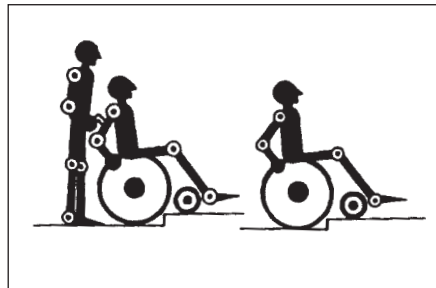

GLIDE

Rehabilitation Products

SECTION 14.2**OPERATION OF WHEELCHAIR**

Descending from obstacle:

Descending from shallow obstacles can be dealt with by rolling forward and keeping the body in an upright position.

Higher obstacles can be dealt with by reversing. Bring the two large wheels to the edge of the obstacle and slowing easing down using the push rim as a brake and the body leaning forwards to avoid tipping.

WARNING!

Descending stairs unattended is not recommended and should be as a last resort and done with extreme caution. Where possible, elevators or access ramps should be used. If however, it is necessary to descend stairs, the push handles are only to be used by the attendant to stabilize the chair and occupant during the descent. Rate of descent, should be controlled by the occupant using the rear wheel push rims.

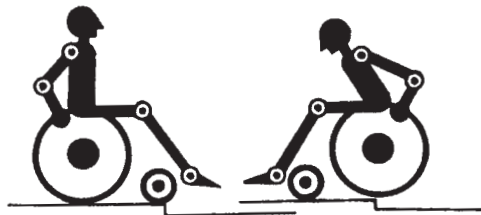



Rehabilitation Products

SECTION 14.3

Static ability

Reaching forward, to the side or to the back of the wheelchair will affect the stability of the wheelchair.

Do not take risks, especially when chair is not on a level plane.

SECTION 15

To date there is no recognized Australian Standard that covers wheelchairs suitable for vehicle transport while the user is in the chair. However the Series 2 is suitable for transport provided the appropriate tiedown brackets are fitted to the chair and a 4 point restraint system (Unwin) is used. Where possible, wheelchair occupants should be transferred into and use the proper vehicle seat and restraints. However, if your chair is to be

transported in a vehicle, your vehicle restraint system must comply with AS2942-1994.

CAUTION:

Do not use legrests or footplates as attachment points for your tie down system. Do not use armrests as attachment points for your tie down system. Unoccupied wheelchairs in vehicles must be safely secured or stored securely outside the passenger compartment. Posture Positioning Belts should not be used as vehicle restraint belts.

NOTE:

Ensure that your restraint system complies with AS2942 and you fully understand the manufacturer instructions on how your tie down system works and whether it is compatible with the Glide Manual Chair.

GLIDE

Rehabilitation Products

SECTION 16**OPTIONS**

Listed below are some of the common options available. Options can be supplied in lieu of parts when ordering a new wheelchair or sold as a spare part at a later date.

- Elevating leg rests
- Tray
- Crutch holder
- Quick release hubs
- Arm trough
- Desk arms
- Adjustable height arms
- Heel loops
- Pneumatic castors
- Thorn resistant tubes (large wheel)
- Spoke guards
- Anti tip bars
- Oxygen bottle carrier
- Brake extension
- Lambs wool covers
- I.V. poles
- Head rest extension
- Stump support
- Seat belt
- Contact your supplier for more options



Rehabilitation Products

SECTION 17

SERVICING

Weekly

- Cleaning and care of upholstery as described in (section 3).
- Check the pressure and condition of tyres. Do not exceed maximum pressure advised on side of tyre.
- Service quick release axle if applicable (section 8).

Every 3 months

- Check castor play (section 6).
- Check brakes and adjust if necessary (section 9).
- Ensure that all nuts and screws are tight.
- Check rear wheels for loose spokes. Spokes should be tightened by an experienced wheel builder.
- Regular cleaning will restore your wheelchair to its original finish.

Every year

- We advise that your wheelchair be serviced by an approved dealer at least once a year. This will ensure that your wheelchair is in a safe operating condition.

GLIDE

Rehabilitation Products

SECTION 18**WARRANTY**

Lendal Pty Ltd (trading as Glide Rehabilitation products) warrants the following as listed:

Frame

3 -Year Warranty

Frame will be replaced within the first 12-month period. Thereafter, Glide Rehabilitation Products will extend the warrant for a further two years and will either replace or repair frame.

Controllers – where applicable

12-months warranty

Controllers and associated hardware will be repaired where possible. Replacement will only occur if repair is not practical or not possible.

Actuators/Motors/Gearbox – where applicable

12-months Warranty

Automatic replacement within six months of invoice. There afterwards, unit must be returned for evaluation and possible repair before replacement.

Upholstery – (including armrest pads)

6 Month Warranty

This will cover against defects in materials or workmanship. Warranty does not cover against normal wear and tear or damage.

Tyres and Tubes

No Warranty

Parts

Components replaced during the warranty period will be warranted for the

remainder of the warranty period

Spare Parts and Accessories

All spare parts and accessories sold will have a 6month warranty period from date of purchase.

Receipts are required to support warranty claims.

Conditions

Under normal circumstances no responsibility will be taken for the repair or replacement of the product that has not been maintained in accordance with manufacturers recommendations or is not as a direct result of an original manufacturing defect.

Lendal Pty Ltd (trading as Glide Rehabilitation Products) warrants all manufactured and distributed products against defects in materials and workmanship for a period of one year or for a period otherwise stated in this warranty from date of purchase.

Lendal Pty Ltd will repair or replace any part, as required, provided the purchased product is delivered intact and prepaid to a location authorised by Lendal Pty Ltd within the prescribed period of warranty.

This warranty does not extend to parts or components damaged by misuse, neglect, accident or improper installation, nor those tampered with, altered or serviced by an agency not authorised by Lendal Pty Ltd.

The foregoing in lieu of all other warranties expressed, implied or statutory, Lendal Pty Ltd's sole liability shall be to repair or replace parts of components as specified above.



Rehabilitation Products

SECTION 18 - 1

IMPORTANT

1. Lendal Pty Ltd (trading as Glide Rehabilitation Products) does not warrant either expressly or impliedly the suitability of the wheelchair for the purchaser or any intended user. Purchasers and intended users are advised that advice from an appropriate registered medical practitioner or health professional should be obtained prior to using the wheelchair.
2. Except insofar as is prohibited by statute, Lendal Pty. Ltd. shall not be responsible for damage, injury or loss of any kind to any property or person howsoever caused arising from or in connection with the Glide Rehabilitation Products wheelchair. All conditions and warranties that (but for this provision) would be implied in favour of, and all rights and remedies that (but for this provision) would be conferred upon the purchaser or other persons against Lendal Pty. Ltd. arising under or as a result of the Trade Practices Act 1974, any other legislation or the general law are excluded and limited to the maximum extent possible and in cases where Lendal Pty. Ltd's liability cannot be completely excluded but may be limited, the liability of Lendal Pty. Ltd is limited to one of the following (at the option of Lendal Pty. Ltd.)
 - a) The replacement of the Glide Rehabilitation Products wheelchair or the supply of an equivalent wheelchair
 - b) The repair of the Glide Rehabilitation Products wheelchair
 - c) The payment of the cost of replacing the Glide Rehabilitation Products wheelchair or of acquiring an equivalent wheelchair
 - d) The payment of the cost of having the Glide Rehabilitation Products wheelchair repaired



Rehabilitation Products

SECTION 18 - 2

WARRANTY

The following details will be required when making a warranty claim. Make sure all the relevant details are filled in at time of purchase.

Name _____

Address _____

City _____

Purchased by (e.g. Hospital) _____

Serial No. _____

Purchase Date _____

Series/Model No. _____ Size _____

Dealers Name _____

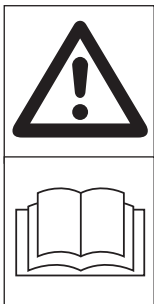

READ THE OPERATOR &
INSTRUCTION MANUAL

CE

GLIDE

Rehabilitation Products

Glide Rehabilitation Products are manufactured in Australia by Lendal Pty. Ltd. (ACN 009 033 694)
25 Ledger Road, Balcatta, Western Australia 6021
Phone: +61 8 9345 3400 Fax: +61 8 9345 1318
Email: info@glide.com.au Web: www.glide.com.au

ABN 60 157 412 811

A WHOLLY OWNED AUSTRALIAN COMPANY



APPLY BRAKES
WHEN
TRANSFERRING
PATIENTS