

# JoyGlide User Manual

2021 VERSION



## IMPORTANT

For your safety and comfort read carefully and understand all of the features prior to using your new Glide Rehabilitation Products chair.



# **TABLE OF CONTENTS**

**SECTION 1. INTRODUCTION**

**SECTION 2. STANDARD FEATURES**

**SECTION 3. GENERAL WARNINGS**

**SECTION 4. CHARGING THE BATTERY**

**SECTION 5. USING THE HANDRIMS FOR OPERATION**

**SECTION 6. REMOVING THE WHEELS**

**SECTION 7. MAINTENANCE**

**SECTION 8. SPECIFICATIONS**

**SECTION 9. WARRANTY.**

## **SECTION 1. INTRODUCTION**

Thank you for choosing the Glide Rehabilitation Products Power Assist Wheelchair.

With proper care and operation your wheelchair will provide years of trouble free mobility.

**Please** take the time to familiarise yourself with the functions and features of your power assist chair by reading this owners manual. If you have any queries about the functions of the chair you can call Glide Rehabilitation Products or your nearest Glide Rehabilitation Products dealer.

### **GLIDE REHABILITATION PRODUCTS**

**25 LEDGAR RD  
BALCATT  
PERTH. WA. 6021  
AUSTRALIA  
PH +61 8 9345 3400  
Fax +61 8 9345 1384**



## SECTION 2. STANDARD FEATURES

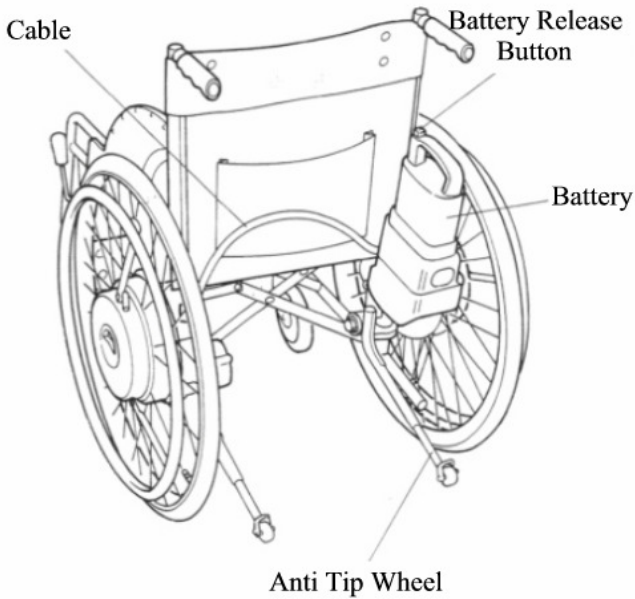
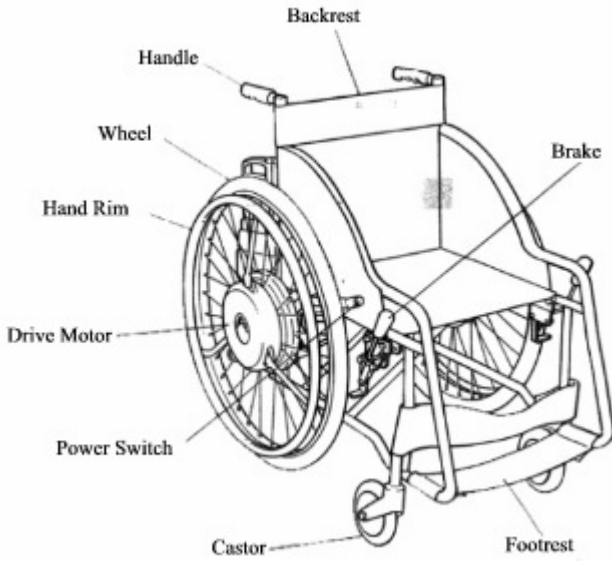

## **SECTION 3. GENERAL WARNINGS**

### **WARNING**

Understand the characteristics of the Power Assist Unit before using.

- Do not lift the front castors using the hand rims while the power is on. Always turn the power off before lifting the castors
- Do not operate power assist unit in wet conditions. Hand rims tend to slip when wet.

### **WARNING**

Always be accompanied by an attendant in the following situations.

- Crossing railway lines. (There is a possibility of castors catching in the tracks)
- Cross – hatched covers on side ditches or drainage ditches. (There is a danger of the castors catching in the cover)
- Do not go down hill with the power unit turned off. (There is danger when the speed increases to the point where you cannot stop by yourself)
- Areas where the chair inclines sharply to the right or left
- Other areas that you are unfamiliar with the environment.

### **WARNING**

Traveling without the anti-tip rollers fitted or traveling with the anti-tip rollers incorrectly adjusted may cause a rollover. Always ensure that they are fitted and adjusted correctly. When adjusted correctly you will have approximately 75mm clearance between the floor and the anti-tip roller when chair is fitted with 175mm diameter front castors.

### **WARNING**

Crossing roads and riding on the shoulder of the road may involve danger. Always be accompanied by an attendant when travelling in unfamiliar areas.

- Pay attention to traffic from the right and left when crossing roads without pedestrian signals.

## **WARNING**

When the battery warning light blinks and the buzzer makes a “beeping” sound, replace the battery as soon as possible. If you continue power assisted travel and the battery completely runs out, the battery warning light will come on and the buzzer will make a beeping sound. The Power Assist Unit will come to a stop. It is very dangerous when you get into a situation where you can’t move about. Make sure to replace the battery, using the following procedure.

- Move to a safe area. Then turn the power off and replace the battery with the spare battery. If you do not have a spare battery with you, travel with the power turned off.
- If you cannot replace battery by yourself have an attendant help you.

## **WARNING**

If the battery warning light suddenly comes on and the Power Assist System comes to a stop, with the buzzer making a “beeping” sound during operation, there may be a malfunction in the system. Stop power assisted travel.

## **WARNING**

Adding modifications to the JW-2 unit or to the mounting portion may adversely affect its performance or safety. Never add modifications.

- If you feel something is wrong, contact your nearest agent or Glide Rehabilitation Products.

## **WARNING**

It is very dangerous to let children or people who do not know how to operate it ride in this wheelchair. Make sure to detach the battery when it is not in use.

## **WARNING**

Do not hold (or let anyone hold) the hand rims, battery, or cable when lifting (or having someone lift) the wheelchair. This may cause damage to the unit. There is a danger of a rollover or a fall, especially when

lifting with someone in the wheelchair. Be sure to follow the following precautions.

- Lock the brakes so the wheels do not spin
- Turn off the power
- Always hold the frame portion of the wheelchair when lifting.

### **WARNING**

The JW – 2 has a small sized battery but it stores a large volume of energy. Incorrect use may cause damage to the unit or, depending on the situation; it may cause a burn or fire.

- Use the specified charger (JWC – 2) when charging the battery.
- Always put on the protective cap when the battery is not in use.
- Do not connect the (+, - ) terminals of the battery with the wires or other metals.
- Avoid sharp impact to the battery, and do not disassemble or modify it.
- Do not use the battery on units other than the specified equipment.
- Do not heat or throw the battery into fire or water.
- Use the specified fuse.
- Keep the battery out of reach of children and third parties.

### **WARNING**

Never take chair onto stairs or escalators

## SECTION 4. CHARGING THE BATTERY

This section presents basic information on the characteristics of the battery designed for the JW-2, and on the dedicated charger for the unit.

### List of names of parts of the battery

1. Capacity display lamp. The charging and discharge statuses, and any problems that occur, are displayed here.
2. Display Switch
3. Release Button. This button releases the battery from the unit.
4. Battery Fuse. This fuse protects the battery, and should not be removed unless there is a problem with it.
5. Contact points. Current and battery information is transmitted by the contact points.

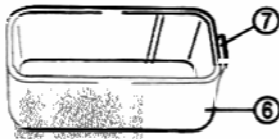
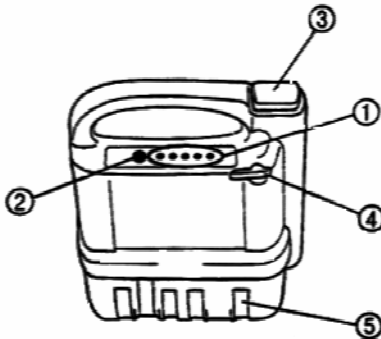

6. Protective Cap. This prevents short-circuits and protects the contact point
7. Spare Battery Fuse. This can be used as a replacement if the main unit fuse blows



## **Battery Characteristics**

1. The travel distance may be shorter than usual, depending on the terrain, temperature, and the method used to charge the battery.
  - When using the wheelchair in locations where there are frequent inclines and numerous curbs, the battery consumes more power than under ordinary travel conditions, resulting in a shorter travel distance.
  - At low temperatures, battery operation is somewhat weaker, and the travel distance is shorter.
  - If the battery is repeatedly charged before it has completely run down, the capacity decreases, and the travel distance is shorter. (If refresh charging is done properly, this can be avoided)
  - The above problem is particularly likely to occur if the battery is charged with a high ambient temperature. (The recommended ambient temperature range is 10 to 30 degrees C.)
2. Even if the battery is correctly used, the performance deteriorates gradually with the passage of time.
  - The service life of a nickel hydrogen battery varies depending on the way it is used, but is approximately one year or 300 cycles. (This can also be judged by looking at the capacity display after the battery has been charged.)
  - As the level of deterioration advances, the capacity display becomes less stable. We advise consulting the dealership where the battery was purchased, and replacing it with a new one without waiting until deterioration has proceeded too far.
3. The capacity diminishes naturally even if the battery is not used (self discharging).
  - Even if the battery is not used for a long period of time, the remaining capacity display should be checked periodically, and the battery recharged at appropriate intervals. If the battery is being stored for a long period of time and it is not possible to charge it, the fuse should be removed from the battery, to suppress self – discharging. (When the fuse is removed, the capacity display lamp no longer lights correctly, but operation returns to normal when the battery is charged again.)

- Self – discharging is affected by the temperature at which the battery is stored, and accelerates at high temperatures. (0 to 30 degrees C is the recommended storage temperature range.)
- If the JW – 2 is stored with the battery installed, a small amount of battery power continues to be consumed. If the JW – 2 is not to be used for a long period of time, the battery should be removed and stored separately.

### Names of parts of the charger

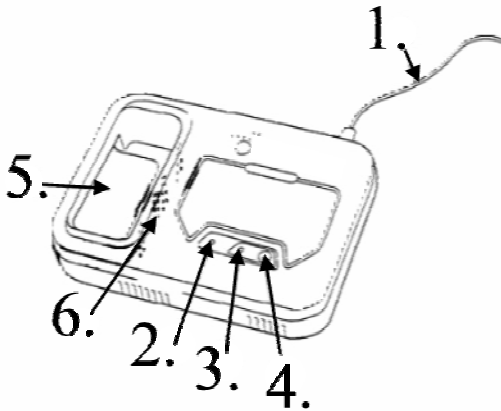

1. Power supply cord. This supports an input power supply of 100 to 240 VAC, 50/60Hz.
2. Charging lamp (Green). This lights while the battery is charging, and flashes in stand-by mode.
3. Refresh lamp (Yellow) .This flashes when refresh charging is needed and lights during refresh charging. If a problem occurs, both lamps flash to alert the user.
4. Refresh switch. This is used if the refresh lamp is flashing.
5. Battery insert inlet
6. Contact points (in 4 places). These transmit current and battery information

## **Functions of the dedicated charger**

1. When refresh lamp is flashing alerts the user to the refresh charging timing. If nickel hydrogen batteries are charged after they have completely discharged, the battery performance can be recovered, and a shortening of the travel distance can be avoided. The dedicated charger reads information from the battery on the refresh charging timing, and notifies the user by means of the display lamps.
2. Charging is controlled by means of temperature information. The temperature of the battery when it is charged significantly affects the service life of the battery. The dedicated charger reads temperature information from the battery and controls charging based on that information.
3. Alerts the user to battery and charger problems. If a problem occurs with the battery or the charger during charging, the display lamps flash, notifying the user of the location of the problem.
4. Worldwide voltages supported. The charger supports input power supplies ranging from 100 to 240 VAC, 50/60 Hz. (An adapter for the power supply plug may be necessary in some counties.)

## **Select a place to Charge**

Select one of the following places to charge the battery.

- A cool and well ventilated place indoors.
- A location where the temperature can be kept at 10 to 30 degrees C while charging.
- A level and stable place.

## **CAUTION**

**Avoid the following areas.**

- **High temperature areas such as exposed to direct sunlight or near a stove. In cold regions, where the temperature drops to below zero in the winter. Charging will not start when the battery temperature is too high or too low.**

- **Outdoors where it is exposed to rainfall or near a sink where water may splash. This may cause a short circuit or electric shock.**
- **Do not place objects on or around the charger. The charger will generate heat during charging, and this may adversely affect its function.**
- **Within reach of children or pets. May cause injury or damage to the unit.**

### **Install the battery in the Charger**

**Use only the specified charger (JWC-2). Failing to do so may cause fire or damage to the unit.**

1. Hold the plug and plug in the power cord of the charger to a 240V household outlet.
2. Confirm that the power switch of the charger is turned off.
3. Before charging, allow the battery to cool naturally until it feels cool to touch. 10 to 30 degrees C is the appropriate temperature range for charging.

### **Caution:**

To protect the battery, a hot battery will not start charging until the battery is cooled off to an appropriate temperature. The battery, immediately after use on a hot summer day, is likely to be hot. Cool the battery to an appropriate temperature before charging it.

4. Insert the battery firmly until it hits the battery insert inlet of the charger.

### **WARNING**

**Do not drop or jolt the battery. This may cause it to malfunction.**

### **Caution:**

- **Do not put your hands or other objects in the battery insert inlet.**
- **Check that there are no foreign objects in the battery insert inlet. Remove any objects before installing the battery.**
- **Do not deform or damage the connecting point of the charger.**

## **Start Charging**

There are two ways to charge the battery: “**rapid charging**”, in which the battery is charged in a short time, and “**refresh charging**”, in which the battery is charged while recovering the battery performance.

## **Rapid Charging Procedure**

1. Turn on the power after installing the battery. If the battery temperature is appropriate, the charging light (green) will light, and charging will start. Charging is completed in approximately one to two hours.
2. When the battery temperature is (40 C or above) or low (0 C or less), the stand – by light (yellow) will light until the battery reaches the appropriate temperature. When the battery temperature is appropriate, the charging light (green) will light, and charging will start automatically. The stand-by time will vary depending on conditions, but it will take approximately one to two hours.
3. When charging is completed, the charging light (green) will go out automatically.

## **Caution**

**Do not charge a battery that is already charged. The temperature will increase and it will shorten the life of the battery.**

## **Caution**

**As the deterioration of the battery advances, some of the display lamps no longer light, even though the charger has been completed. First the 5<sup>th</sup> light fails to light, then the 4<sup>th</sup>, and so on. If the 5<sup>th</sup> and 4<sup>th</sup> lamps no longer light after charging has been completed, the battery should be replaced.**

## **Refresh charging Procedure**

1. Install the battery in the charger and turn on the power.
2. The refresh lamp (yellow) flashes when refresh charging is needed. If the refresh lamp is flashing push the refresh switch while the refresh lamp is flashing (about 10 seconds). Then the refresh lamp comes on and discharging starts.
3. During the discharging, the capacity display lamp indicates the status of discharging.
4. Discharging automatically terminates and then charging starts. (The charging process is the same as the rapid charging.)

### **CAUTION**

If you disregard the refresh charging alert and continue rapid charging, the capacity display lamp may go off inaccurately. Make sure refresh charging is done before the third alert.

### **NOTE**

- Refresh charging normally takes 3 to 13 hours. (In case of high temperatures, it may take longer.)
- It is a good idea to do refresh charging while sleeping.
- If the refresh lamp flashes but you have no time for refresh charging, you can do rapid charging instead of refresh charging.
- If the charger is not touched for 10 seconds, rapid charging starts.

## Problems during Charging

If a problem occurs with the battery or the charger during charging, the “Charging” lamp and “Refresh” lamp on the charger, and the battery capacity display lamp, light to alert the user to the problem.

BATTERY	CHARGER	FAULT
1 <sup>ST</sup> , 3 <sup>RD</sup> , and 5 <sup>TH</sup> light flashing		The temperature of the battery is not appropriate for charging. Wait until the battery temperature has reached an appropriate level before beginning to charge it.
4 <sup>TH</sup> Flashing	Both green and yellow are flashing simultaneously	There is a problem inside the battery. Replace the battery with a new one.
	9 green and yellow are flashing rapidly and alternately.	<b>1.</b> There is a possibility of a faulty contact point. Inspect the contact points on the battery side and the charger side, and if there is any dirt or dust, remove it. If the contact points are dirty, wipe them clean with a dry cloth, being careful not to scratch or cause deformation of the contact points. <b>2.</b> There is a possibility that the battery fuse has blown. Open the fuse cover on the side of the battery, and inspect the fuse. If it has blown, replace it with the spare fuse on the protective cap <b>Warning - Using the wrong type of fuse can cause a fire. Use only the specified type of fuse (30A blade fuse). Never use a wire or any other material</b>
	Flashing sequentially in the order of green-green-yellow	There is a problem with the charger. Replace it with a new charger.
	Flashing sequentially in the order of green – green – green - yellow	There is a problem with the charger. Replace it with a new charger.

## **After Charging**

1. When charging has been completed, remove the charged battery.

## **WARNING**

**Store the detached battery with the protective cap on. There is a danger of a short – circuit when the connecting strips/terminals are exposed.**

2. Unplug the power cord from the outlet by holding the plug portion.

## **CAUTION:**

Do not pull on the power cord. This can cause breakage to the wires.

3. Storing the battery for a long period.

If the battery is stored for a long period, the battery capacity will decrease due to self discharging. Before using it, recharge any battery that has not been in use for over one week.

4. Recycling the battery

Dead batteries are valuable resources that can be recycled. Contact the dealer shop when asking for recycling.



## SECTION 5. USING THE HAND RIMS FOR OPERATION (TYPE A & TYPE B)

### 1. Before Use

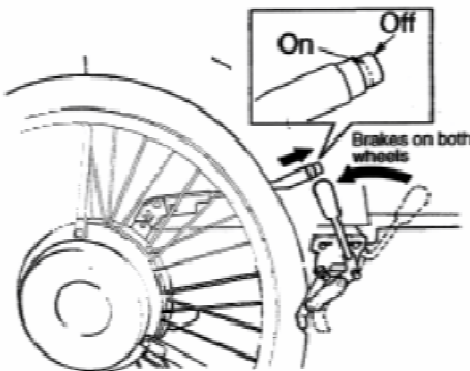
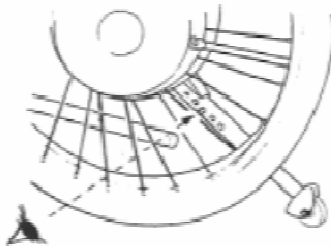
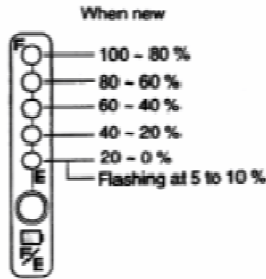

1. Check the remaining battery capacity, pressing the display switch to confirm the capacity on the display lamps. When the display switch is pressed, the lamps light for several seconds. **NOTE:** The remaining battery capacity is displayed in a 5 step display (when new).

As the deterioration of the battery advances, some of the display lamps no longer light, even though the charging has been completed. The travel distance also decreases.

2. Check to see if the anti - tip wheel has been properly installed.

**WARNING: Traveling without the anti - tip wheel, or with the wheels set to a shorter than "correct length" may cause a rollover. Never travel without making adjustments.**

3. Get in the wheel chair  
**WARNING: There is a danger of the wheelchair moving unexpectedly, causing a rollover or a fall if you get in and out of the wheelchair incorrectly. Be sure to get in and out of the wheelchair using the proper procedure as described by your therapist.**

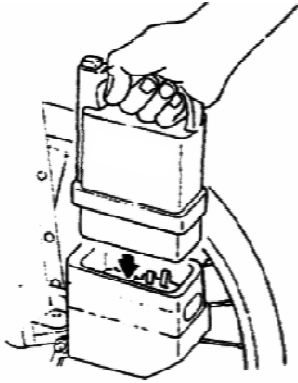

4. Confirm that the power switch is turned off, and install the battery. Insert the battery until it makes a “clicking” sound.

**WARNING:** Do not drop or jolt the battery. This can cause malfunction

**CAUTION:** Do not put your hands or other objects in the battery insert inlet.

Check that there are no foreign objects in the battery insert inlet. Remove any objects before installing the battery.

Do not deform or damage the contacting points.

5. Sit tightly so you will not fall off the wheelchair.

**CAUTION:** Do not forget to wear a seat belt if you usually use it.

---

## **STARTING & STOPPING**

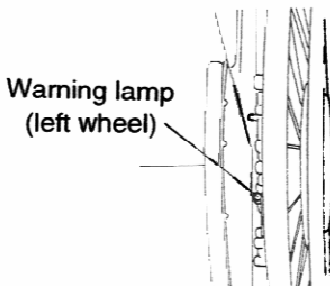
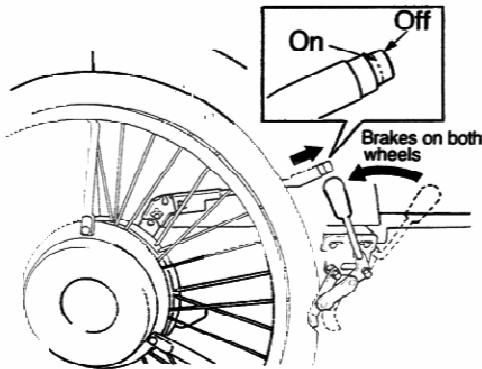

## **Starting and Stopping cont'd**

1. Confirm that the brakes for both wheels are locked.
2. Turn on the power switch. Power assisted travel is enabled when the RED light goes out after a long beep.

### **NOTE:**

- After the warning lamp has lighted for 3 seconds, it flashes the same number of times as the number of battery capacity display lamps, at intervals of 2.5 seconds, and then repeats this twice, to alert the user to the remaining battery capacity.
  - If force is applied to the hand rims when turning on the power, a warning beep will be heard and the safety system will be activated, inhibiting travel. Stop applying force to the hand rims, and turn on the power again.
  - You cannot ride the wheelchair if the “RED” battery warning light is on immediately after replacing the battery. There may be a malfunction in the system. Contact your nearest dealer or agent.
3. Release both brakes.
  4. Before traveling, be sure you understand the characteristics of the Power Assist System, and then make every effort to ride safely.

## SECTION 6. REMOVING THE WHEELS

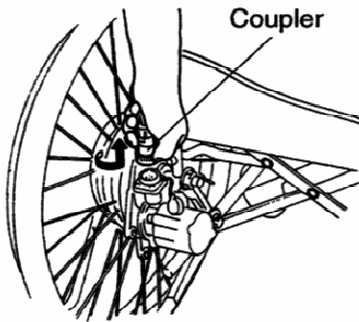
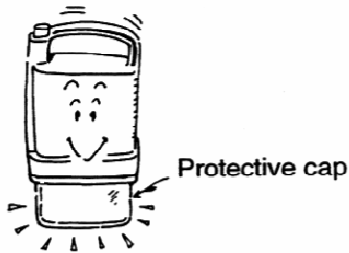

1. Detach the battery so the power will not turn on during operation.

**WARNING: Store the detached battery with the protective cap on. There is a danger of a short circuit when the contacts are exposed.**

2. Pull of the coupler of the left wheel by slightly turning the end.

**NOTE:** Wind the removed coupler to the right wheel to prevent it from being damaged.

3. Lift the cam shaft lever on the left wheel. Pull the lever and remove the wheel.
4. If necessary, remove the right wheel by following the same procedure.

**CAUTION:** Remove the wheel by holding onto the battery storage so the wheel will not spin. Depending on the circumstances, the battery and other components may be damaged if the wheel spins when it is removed.

### **ATTACHING THE WHEEL**

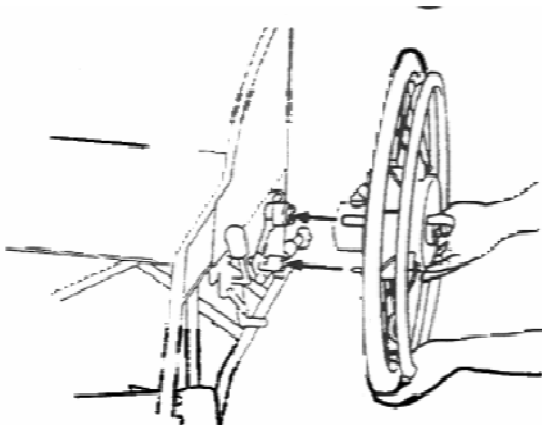

1. Insert the axle end to the frame mounting portion with the cam shaft lever of the left wheel lifted. Then match the torque stop portion and fit the wheel in place.
2. Mount the right wheel by following the same procedure.
3. Push in the coupler by matching the portion (WHITE) of the coupler to the mark on the insert inlet.

## SECTION 7. MAINTENANCE

1. Store the wheelchair with the battery detached

### **WARNING**

**It is very dangerous to let children or people who do not know how to operate it ride this wheelchair. Make sure to detach the battery when it is not in use.**

### **WARNING**

**Store the detached battery with the protective cap on. There is a danger of a short-circuit when the contacts are exposed.**

**NOTE: When not using the wheelchair for a long period, discharge the battery completely.**

2. Wipe off any water drops with a dry towel after traveling on a wet road surface after the rain. Leaving the wheelchair wet can cause some parts of the chair to rust.

**CAUTION: Never spray water directly onto the wheelchair. This can cause malfunctioning of electrical parts.**

3. Store the wheelchair indoor where there is less humidity

**CAUTION: Do not store the wheelchair where it is subject to rain, direct sunlight, or high humidity. This can cause malfunction.**

4. Avoid storing the battery in places with high temperatures.

**CAUTION: Do not leave the battery inside the car for a long period of time in direct sunlight.**

## **INSPECTION AND ADJUSTMENT**

### **Anti-tip wheel and Bar**

### **WARNING**

**Traveling without the anti-tip bar or with the bar shorter than the “standard length” may cause a rollover. Never use the wheelchair without the anti-tip wheel and bar adjusted to the correct height**

1. Be sure to secure the anti-tip bar until the pin comes out with a “click” sound.
2. Check that there is 5 to 10 cm of space between the castors and the ground surface, with the small wheel at the end of the anti-tip bar touching the ground. If the space is too small or too large, adjust the bar to one of the holes above or below.

## **TYRE AIR PRESSURE**

Tyre size – 24” x 1 3/8” = 55 PSI

## **INSPECTION OF THE WHEELCHAIR BODY AND WHEELS**

### **WARNING**

**Continuing to use the wheelchair with a problem in the wheelchair body or the wheels may cause sudden damage to the wheelchair while traveling, and may result in a rollover or the wheelchair being upset.**

Always check the condition of each part of the wheelchair. If you detect any problems, have the wheelchair inspected and repaired by the dealer.

- Crack in the frame
- Loosening of components
- Loosening or breakage of the spokes
- Effectiveness of the brakes
- Deformation of the castors
- Wear of the tyres

## SECTION 8. SPECIFICATIONS

<b>Specifications of the Power Assist System</b>	<b>2 Types (Type A and Type B)</b>
Unit Weight	15.8 kg (Type A)
Power Assisting Range	0 to 6 km/h
Travel Distance on one charge	15 km or more (Type A)
Motor	24 V 90W x 2
Drive Train	Wheel in type, direct rear wheel drive
Steering Method	Right and Left hand rim steering
Tyre Size	24 x 1 3/8

### **Charger**

Power	100 to 240 V, 50/60 Hz
Fixed Output	36 V, 2.6A (when charging)
Battery	JWC – 2 specified battery, (nickel hydrogen, 24V x 6.7Ah, 30A blade fuse)
Charging Time	Rapid Charging approximately 2 to 3 hours Refresh Charging approximately 3 to 13 hours
Ambient operating temperature	0 to 40 degrees C

**The travel distance varies greatly depending on the terrain and travel conditions.**



## **SECTION 9. WARRANTY**

Lendal Pty Ltd (trading as Glide Rehabilitation Products) warrants all manufactured and distributed products against defects in materials and workmanship for a period of one year from purchase date. Electrical components are warranted for six months. Lendal Pty Ltd will repair or replace any part, as required, provided the purchased product is delivered intact and prepaid to a location authorised by Lendal Pty Ltd within the prescribed period of warranty.

This warranty does not extend to parts or electrical components damaged by misuse, neglect, accident or improper installation, nor those tampered with, altered or serviced by an agency not authorised by Lendal Pty Ltd.

The foregoing in lieu of all other warranties expressed, implied or statutory, Lendal Pty Ltd's sole liability shall be to repair or replace parts of components as specified above.

### **IMPORTANT**

1. Lendal Pty Ltd (LENDAL) does not warrant either expressly or impliedly the suitability of the Glide Power Assist Wheelchair for the purchaser or any intended user. Purchasers and intended users are advised that advice from an appropriate registered medical practitioner should be obtained prior to using an electric wheelchair.
2. Except insofar as is prohibited by statute, Lendal shall not be responsible for damage, injury or loss of any kind to any property or person howsoever caused arising from or in connection with the Glide Power Assist Wheelchair. All conditions and warranties that (but for this provision) would be implied in favour of, and all rights and remedies that (but for this provision) would be conferred upon the purchaser or other persons against Lendal arising under or as a result of the Trade Practices Act 1974, any other legislation or the general law are excluded and limited to the maximum extent possible and in cases where Lendal's liability cannot be completely excluded but may be limited, the liability of Lendal is limited to one of the following (at the option of Lendal)
  - a) The replacement of the Glide Power Assist Wheelchair or the supply of an equivalent wheelchair
  - b) The repair of the Glide Power Assist Wheelchair
  - c) The payment of the cost of replacing the Glide Power Assist Wheelchair or of acquiring an equivalent wheelchair
  - d) The payment of the cost of having the Glide Power Assist Wheelchair repaired



25 Ledger Rd Balcatta  
Western Australia 6021  
Phone: +61 8 9345 3400  
Web: [www.glide.com.au](http://www.glide.com.au)

Glide Products Pty Ltd

ABN: 28 645 050 255

ACN: 645 050 255

ISO 9001 ACCREDITED